

**H** Insert LED casing

**J** Shorten the length of the resistor by approx. 0.5 cm. Then solder the resistor to the right leg of the LED and the black battery clip cable to the left.

**Visual check:**

First, sit back and relax and let your thoughts wander. And when you are completely relaxed, look at the assembly instructions again from the front and check whether you have done everything as described in the instructions.

**I** 1 Assemble LED

**Warning:**  
The longer leg of the LED must be on the right (R) side!

Insert the LED in the LED casing.

**3** Carefully bend the LED leg with tweezers

1 cm 1 cm  
(0,5 cm) (0,5 cm)

**K** Solder the remaining red to the resistor and then carry out a **visual check**. After that, insert the batteries and test whether it switches on and off.

**2**

1,5 cm

Shorten the LED leg to approx. 1.5 cm

**L** Build the frame

Caution: POSITION

**M** Mount the frame on the (1) plate and then insert (2) the (3) bracket

**N** Insert battery and tuck away the cable

**O** Remove protective film from the acrylic panel, place acrylic panel on the casing and fix with 2 elastic bands

International Morse Code:

A	●—	U	●●—
B	●—●	V	●●●—
C	—●—●	W	—●●
D	—●—	X	—●●●
E	—	Y	—●—●
F	—●●●	Z	—●—●●
G	—●—		
H	—●●●		
I	—●—		
J	—●—●		
K	—●—●		
L	—●—●●		
M	—●—●		
N	—●—		
O	—●—●		
P	—●—●		
Q	—●—●		
R	—●—●		
S	—●—●		
T	—●—		

What is Professor Schlau saying to you in the speech bubble..?

Do you already know about the cool, solar-powered jam-jar lamp?

**Jam-jar lamp,**  
solar-powered, Soldering kit  
Art.no. 78889

With a great lamp effect!

© 2016 C. Reply

Firmenanschrift aufbewahren - Nicht geeignet für Kinder unter 3 Jahren! - Verschluckbare Kleinteile! Keep the address of the company - Not suitable for children under 3 years! - Contains small parts! Veuillez conserver l'adresse - Ne convient pas pour les enfants de moins de trois ans! - Contient de petites pièces pouvant être absorbées! Adres bewaren - Niet geschikt voor kinderen beneden 3 jaar! - Kleine onderdelen Kunnen worden ingeslikt!

SOL-EXPERT group

Art.Nr.: 36500

4037373365005

**Torch, Soldering kit**

**Preparation:**

- Carefully remove the wooden parts from the wooden plate
- Thoroughly check the list of components to check that all pieces are there:

**What else is required:**

Soldering iron, solder, side cutters, tweezers

**We recommend:**

Supervision of the assembly and the soldering process by an adult!

MADE IN EUROPE

## Safety instructions:



- Keep this set of instructions in a safe place for use in the future! It contains important information.
- Should the battery suddenly run out, replace it with a new battery with the same values.
- During soldering, the soldering iron, solder and the component parts which are being soldered are extremely hot. Please be especially careful with them!
- Always use a soldering pad when soldering! This prevents the component parts from sliding around while you are working on them.
- In order to keep the soldering iron secure during assembly, we recommend using a soldering iron stand.
- This assembly set is solely intended to be powered using batteries.

**WARNING:** Never connect the assembly kit to a mains voltage of 230 V! This could seriously pose a danger to your life and cause death or severe injuries!



## The assembly kit for the torch with morse code feature

General: This soldering assembly kit should provide an easy introduction to the basics of soldering. It is perfectly suited for teaching how to solder in schools and workshops. As well as this, the torch assembly kit can be used at summer camps, on summer courses and for other activities to help teach kids how to solder.

### Features of the torch

If the kit has finished being soldered, then it can be used as a **torch**. By inserting an extra button, **morse code can be transmitted with the torch**.

The morse code alphabet can be found in the instructions. If the battery is empty, it can be replaced by the same type of battery.



## Instructions for protecting the environment:

General: Please take the electrical components to a certified waste disposal site when they cease to function. This ensures that the components are disposed of according to legal guidelines. You can actively ensure that the environment is protected by following the regulations in place.

### Battery regulations:

You have purchased a battery-operated product from us. The service life of the battery is limited and must therefore be replaced regularly. Old batteries do not belong in the domestic waste.

Consumers are legally obliged to bring batteries to an appropriate collection point for disposal. Old batteries contain valuable raw materials which can be recycled. You can also send your used batteries to: SOL-EXPERT group, Mehlisstrasse 19, 88225 Baidnt.

## Parts list:

Part	Components	Number
1	wood casing with tool, 8-parts	1
2	Acrylic cover for the casing	1
3	LED white, 5 mm	1
4	LED holder	1
5	Resistor 330 Ohm	1
6	Red cable	3
7	9 V battery 6F22	1
8	Terminal post for 9 V battery	1
9	Button	1
10	Switch	1
11	Screws M2 x 10	2
12	Nuts M2	2
13	Elastic band 32 x 3 x 1.2 mm	2

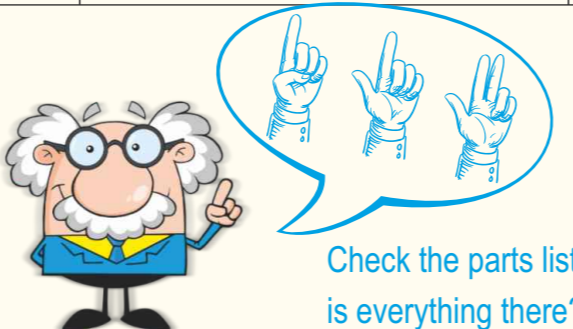

Check the parts list - is everything there??

And now you can start with the:

## ASSEMBLY INSTRUCTIONS



### A Assemble the button

Unscrew the spring washer and nuts

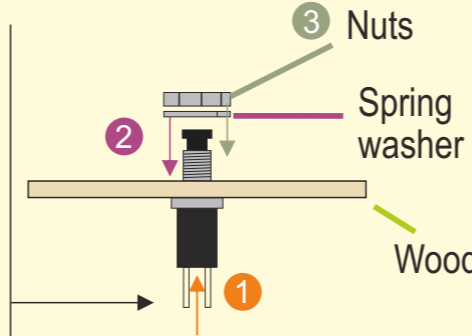
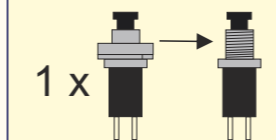

1 x



1 x

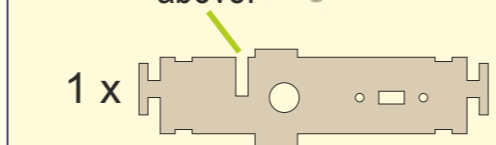

### B Tighten the buttons's nuts with the wooden tool

1 x

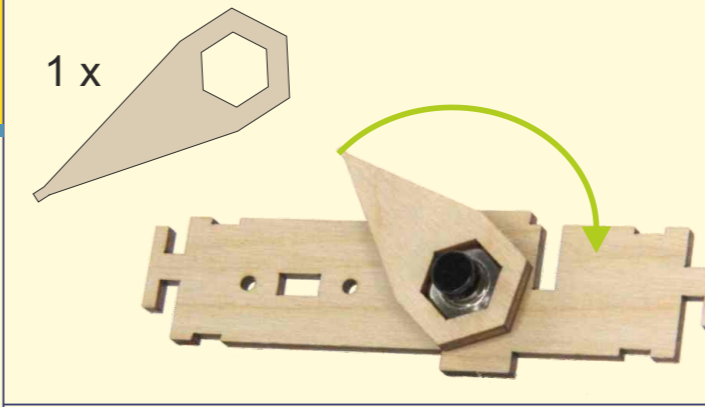

### C Assemble the switch

1 x

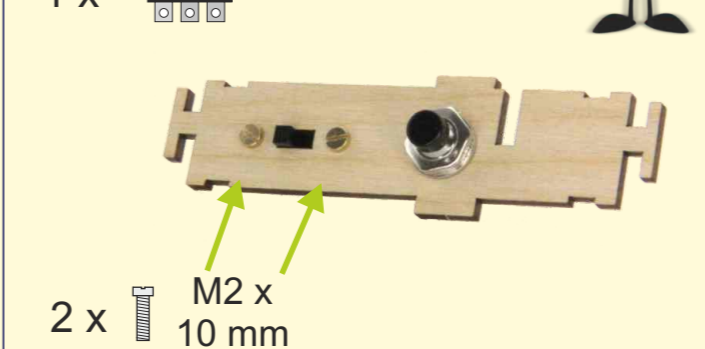

### D

2 x M2



### E

2 x

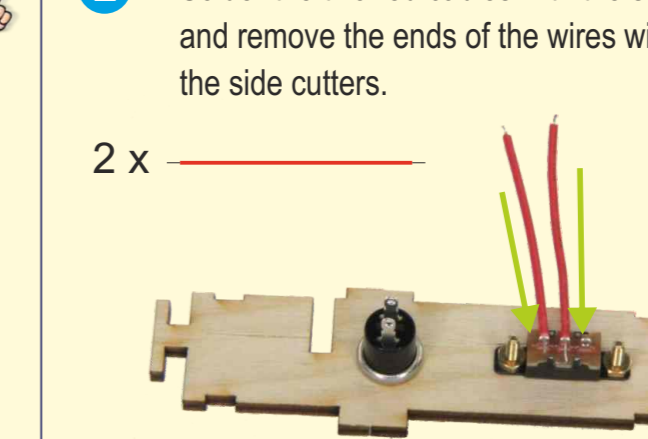

### F

1 x

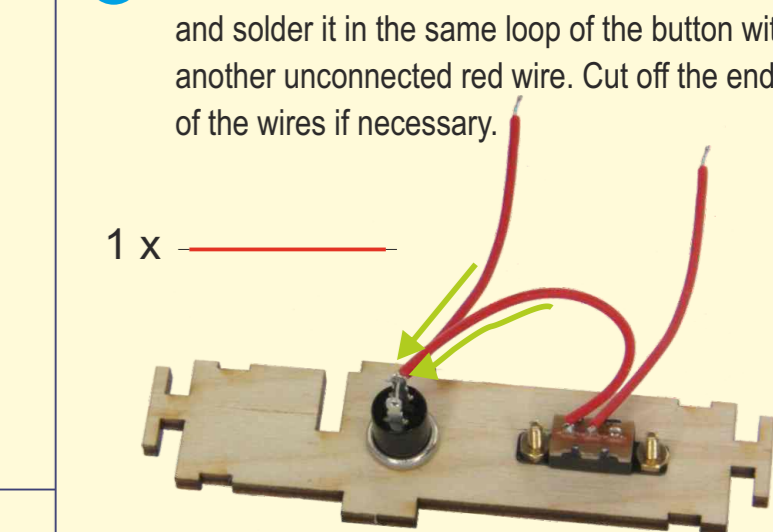

### G

2 x

